

**1582-70M RF SWITCH, DPDT, MANUAL SELECT**

Provides Manual DPDT relay switching between CH1 and CH2 RF signals of two separate RF paths. When power is lost the selected channel is CH1. The Manual Select switch selects CH1 or CH2. LEDs indicate switch position as either CH1 or CH2 and Power.

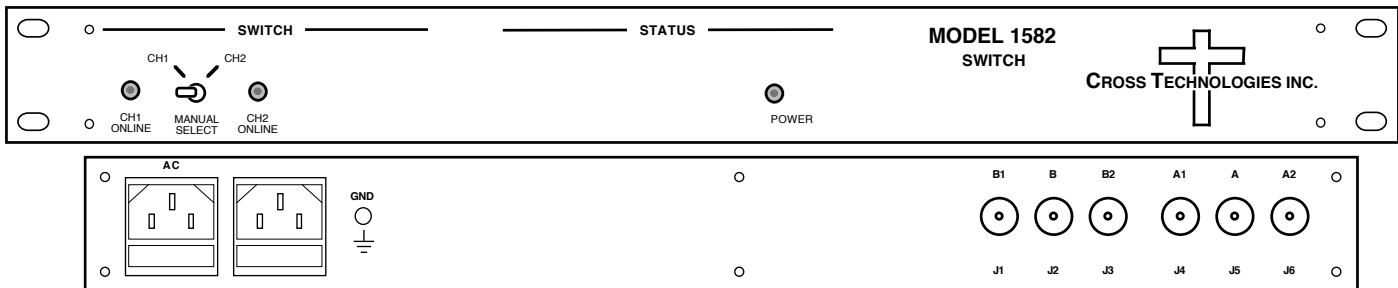

**1582-70M RF SWITCH FRONT AND REAR PANELS**

**1582-70M Technical Specifications**

**Switch Characteristics**

|                |  |
|----------------|--|
| Impedance      | 75 ohms  |
| Type           | Non-latching Relay   |
| Isolation      | >65 dB DC to 10 MHz<br>>50 dB to 1.0 GHz;<br>>40 dB to 1.5 GHz |
| Insertion Loss | ≤1 dB to 1.0 GHz;<br>≤1.5 dB to 2.0 GHz                        |
| Configuration  | DPDT   |

**Controls and Indicators**

|                   |                           |
|-------------------|---------------------------|
| Manual Select     | Manually select CH1, CH2  |
| LEDS (*=Closures) | CH1*, CH2* ON-LINE, POWER |

**Other**

|            |   |
|------------|---|
| Connectors | 75 ohm BNC, female (RF), Other Connectors Available.        |
| Mechanical | 19 inch standard chassis 1.75" high X 12" deep              |
| Power      | Redundant power supplies; 90 - 260 VAC, 47 -63 Hz, 10 watts |

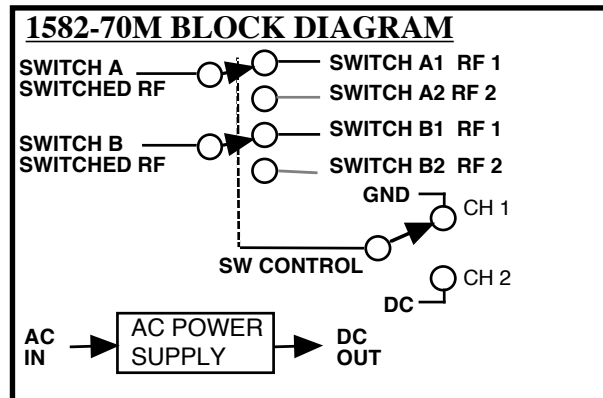

\*+10 to +40 degrees C; 2000 meters max elevation; 80% max humidity; Specifications subject to change without notice